

# MOULTRIE®

## Instructions for 15-Gallon Directional Feeder

THANK YOU for your purchase of the 15-Gallon Directional Feeder. If you should have any questions about this product or any other Moultrie product, please contact us using the information on the back of this sheet. To help us to better serve you, please submit your warranty information online at <http://www.moultriefeeders.com/warranty>

### A ATTACH TREE BRACKET TO HOPPER

Insert a 5/16" x 2 1/2" black oxide bolt through each standoff bracket and into the square tube, each bolt should continue through a curved plate and be secured to inside of hopper with a washer and nut.

**Note:** The top curved plate should be placed on the **inside** of the hopper, and the bottom curved plate should be placed on the **outside** of the hopper.

BOLT PACK x1	MFP80117
FEEDER KIT	MFP80104
HOPPER	MFP80113
CURVED PLATE x2	MFHP81687

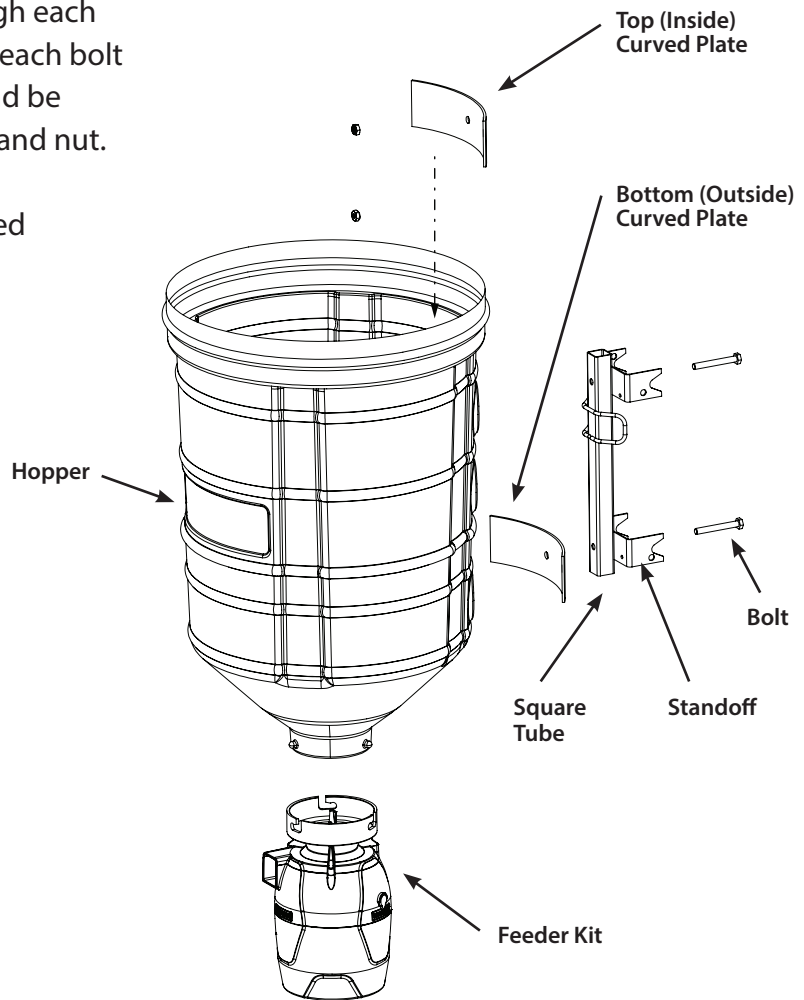

### B MOUNT KIT TO HOPPER

Slide pegs on base of hopper into slots on feeder kit shroud. Rotate counter-clockwise to lock into place.

Feed chute should be oriented away from mounting hardware on hopper.

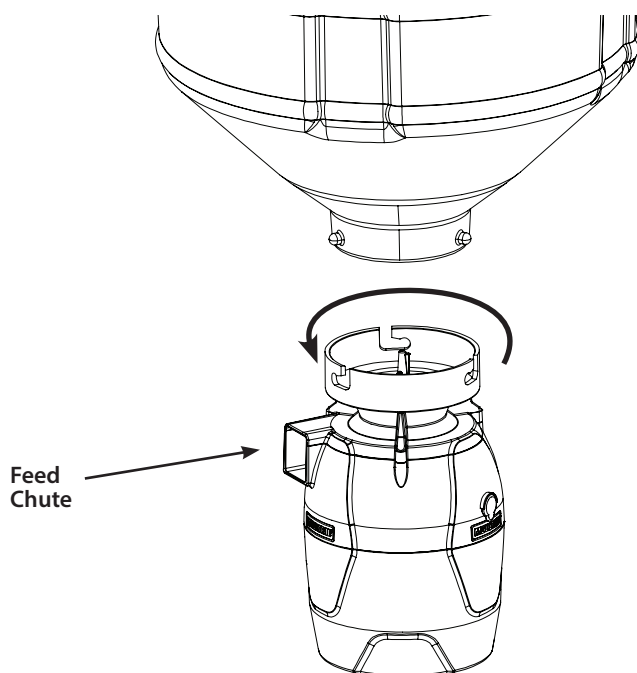



## C MOUNT FEEDER TO TREE

Strap feeder to tree using provided ratchet strap.  
Attach ratchet strap to tree bracket wire loop,  
as shown.

**Note: Hooks must be attached facing  
away from tree.**

RATCHET STRAP x1 MFHP83130  
BRACKET x1 MFP80112

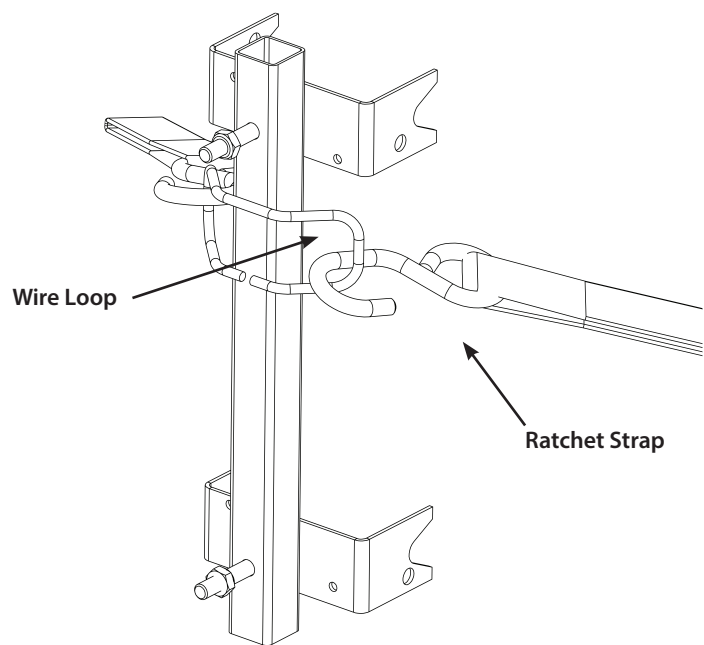

## D MOUNTING FEEDER TO DOCK POST

- 1 Position the standoff bracket against the post.

**Note: Bracket designed to fit 4" x 4" post.**

- 2 Screw 1/4" x 1 1/2" lags through the holes provided on the sides of the brackets as shown, securing feeder to the post.

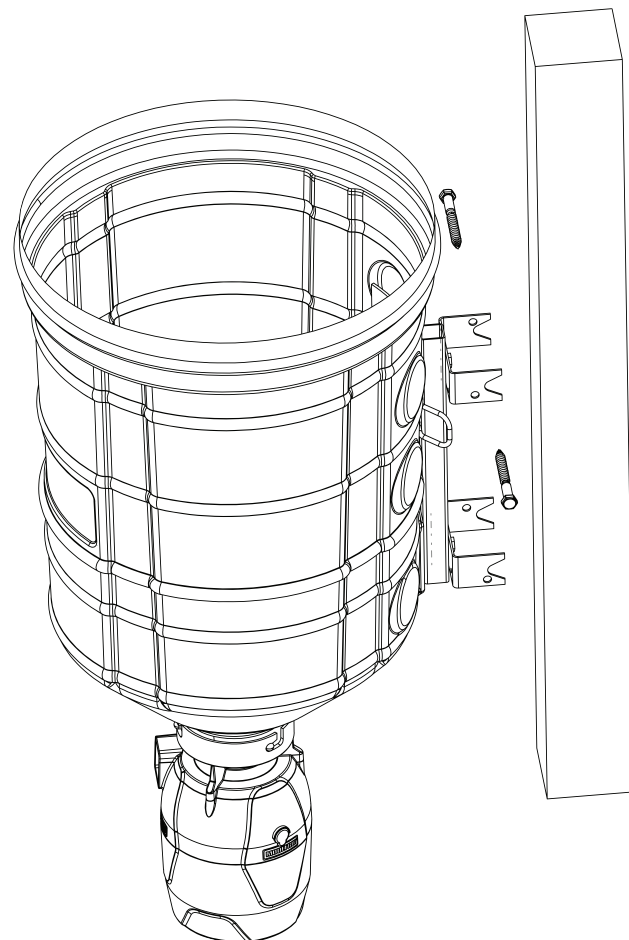

**MOULTRIE®**

CONTACT OUR U.S.-BASED CUSTOMER SERVICE AT  
[www.MoultrieFeeders.com/contact-us](http://www.MoultrieFeeders.com/contact-us)

03212018 / MFG-13076

